

# A continuous flow mass spectrometry technique of argon isotope measurement for K/Ar geochronology<sup>†</sup>

Alexander V. Ignatiev\*, Tatiana A. Velivetskaya and Sergey Y. Budnitskiy

Far East Geological Institute FEB RAS, Pr.100 let Vladivostoku 159, Vladivostok 690022, Russia

Received 24 November 2008; Revised 5 March 2009; Accepted 5 March 2009

**A new method for the measurement of argon isotope composition in a continuous flow of helium for potassium/argon geochronology is described. Extraction of argon from geological samples in multiple-sample holders was carried out in a chamber by heating with a continuous Nd-YAG laser. The extracted and pre-concentrated argon is passed through a chromatographic capillary column in a flow of helium. Argon is separated from possible contaminants in the column and is injected through an open split into the ion source of an isotope ratio mass spectrometer. Measurement of the <sup>36</sup>Ar, <sup>38</sup>Ar and <sup>40</sup>Ar isotopes was carried out in dynamic mode, using a triple-collector ion detector. These experiments have shown that continuous flow mass spectrometry can be used for the analysis of radiogenic argon in picogram quantities with an accuracy that is satisfactory for the solution of many geochronological problems. The method of argon isotope measurement in a continuous flow of helium is an alternative to the measurement of argon isotopes in the static mode. The sensitivity and accuracy of argon measurement by this method are comparable with those provided by the classical static method. The measurement of argon isotopes in a continuous flow of helium is simpler and more reliable than measurement in the static mode. Copyright © 2009 John Wiley & Sons, Ltd.**

The measurement of small amounts of radiogenic argon for dating in geology using the K/Ar technique is the most complex problem in isotopic geology. The K/Ar technique was developed with the purpose of decreasing the errors of mass spectrometric measurements, reducing the quantity of argon needed for analysis, and improving methods concerning argon release and cleaning. The modern techniques of measuring small amounts of radiogenic argon are based on a complex of systems which comply with a number of strict requirements. The systems contain special installations for high-vacuum pumping and cleanup of argon from any extraneous gases, including the high-precision dosing unit of the monoisotope <sup>38</sup>Ar, and a highly sensitive gas mass spectrometer capable of taking measurements of argon in static mode. Special attention is given to heating of the sample up to 1700–2000°C to facilitate the quantitative extraction of argon with an extremely low blank. As an excellent example of a resistance heated furnace, that described by Staudacher *et al.*<sup>1</sup> is particularly satisfactory because of the excellent temperature control and the very low blanks that can be achieved. This type of all-metal furnace has two separately pumped sections. The system is capable of reaching a level of total operating blanks (on <sup>40</sup>Ar) of about 0.008 ng.<sup>2</sup> Measurements of isotope composition of argon are

carried out on high sensitivity gas mass spectrometers capable of operating in a static mode. Mass spectrometric measurements in static mode allow a ten-times reduction of the required quantity of measured argon in comparison with the dynamic mode.<sup>3</sup> However, obtaining argon measurements in static mode is not a trivial task. A recent contribution to this problem has come from laser argon release systems.<sup>4</sup> Using these systems, one can more easily attain a low blank ( $n \cdot 10^{-14}$  g of <sup>40</sup>Ar) and heat the sample for complete argon extraction during tens of seconds.<sup>5</sup>

An overall estimation of the modern techniques of K/Ar geochronology leads to the conclusion that the methods for argon isotope release and cleaning from extraneous gases, and the process of mass spectrometric measurement of radiogenic argon, produce results with a satisfactory accuracy and precision. However, the extraction, cleaning and measurement of small amounts of Ar are extremely difficult and laborious tasks.

## PREREQUISITES OF DEVELOPING THE CF-MS TECHNIQUE OF AR ISOTOPE MEASUREMENT FOR K/AR GEOCHRONOLOGY

The mass spectrometers used to measure the ratios of stable isotopes and argon isotopes are in many respects similar to each other. Therefore, attempts were made to measure the ratios of stable isotopes in the trace amounts of gases (tens of nanograms) using static mass spectrometry.<sup>6</sup> The measurement precision obtained for the isotope ratios was many times worse than that of classical methods.<sup>7</sup> During this time,

\*Correspondence to: A. V. Ignatiev, Far East Geological Institute FEB RAS, Pr.100 let Vladivostoku 159, Vladivostok 690022, Russia.

E-mail: ignatiev@fegi.ru

<sup>†</sup>Presented at the 2<sup>nd</sup> Joint European Stable Isotope User Meeting (JESIUM), Presqu'île de Giens, France, 31 August–5 September, 2008.

Contract/grant sponsor: FEB RAS; contract/grant number: 09-1-OH3-02.

the mass spectrometric measurement of the ratios of stable isotopes, as opposed to the K/Ar technique, has undergone striking changes. Matthews and Hayes<sup>8</sup> proposed a new technique that allows injection of the gas sample directly into a continuous flow of helium (He). The chromatograph gas is then injected into the mass spectrometer for measurement of the ratios of stable isotopes. Over a period of more than 10 years, and following a number of improvements to the technology of isotope ratio measurement, the technique has been used in practically every laboratory dealing with the precise measurements of stable isotopes of oxygen, carbon, nitrogen<sup>9,10</sup> and, in recent years, hydrogen and sulfur.<sup>11–13</sup>

In many cases, this new technology has outperformed the classical methods of isotope ratio determination, mainly due to its simplicity compared with the tedious and laborious methods of sample preparation prevailing before the continuous flow isotope ratio mass spectrometry (CF-IRMS) technique was developed. The reasons for this significant success are that the precision of the CF-IRMS technique is comparable with that of classical methods of isotope ratio determination, it is several times faster, and it has a sensitivity three orders of magnitude higher than that of classical methods.

In the classical system, a measurement is made in pure gases. In the CF-IRMS technique, the sample eluting from the chromatographic column is injected into the ion source of the mass spectrometer in the He flow as a short pulse with a width of 5–30 s. The capillary chromatographic column is designed to clean the sample from other gases and provides a supply of only the test gas into the mass spectrometer in the course of measuring the isotope ratios. The use of capillary columns significantly simplifies the procedure of gas cleaning compared with the cryogenic separation of gases in the classical methods. An open splitter is applied to introduce the gas into the ion source of the mass spectrometer.<sup>14</sup> This equipment was specially developed for fused-silica columns with a diameter not exceeding 0.5 mm.

The important condition for attainment of reliable measurements in methods concerning stable isotopes is a standardization of the measurement process based on the principle of identical treatment (IT) of the measurement conditions of the sample and standard, the *IT Principle*.<sup>15</sup> In the CF-IRMS technique, He is used as a carrier gas and the standard is introduced into the He flow by means of a special device.<sup>16</sup> This problem is successfully solved in the K/Ar technique with the use of an internal standard, the monoisotope <sup>38</sup>Ar.<sup>17</sup>

As an example, measuring the carbon isotopic composition in CO<sub>2</sub> using the CF-IRMS technique with a precision of 0.05‰ requires less than 1 ng of gas.<sup>18</sup> Generally, the required accuracy of the amount of argon measured in K/Ar geochronology is much lower than in other methods, and the determination of an amount of argon (not isotope ratio) with a precision of 1% is quite acceptable. In accordance with Poisson theory, 10 000 ions need to be measured to obtain such precision ( $1\sigma = 1/N^{0.5}$ , where N is the number of ions measured in the ion receiver). Taking into account the fact that the sensitivity of modern isotopic mass spectrometers is less than 1000 atoms per ion (i.e. only one ion of 1000 atoms reaches the Faraday cylinder detector), 10<sup>7</sup> atoms of the isotope should be injected into the source to measure the

signal with a precision of at least 1%. This indicates that continuous flow and the use of a modern isotope ratio mass spectrometer (CF-MS) can measure an amount of <sup>36</sup>Ar equal to  $36 \cdot 10^7 / 6.24 \cdot 10^{23} = \sim 5 \cdot 10^{-16}$  g with a precision of about 1%. In K/Ar geochronology, it is first necessary to estimate the quantity of radiogenic argon, and the measurement of <sup>36</sup>Ar is needed to correct for the <sup>40</sup>Ar in air in order to calculate the quantity of radiogenic argon. Since the abundance of <sup>36</sup>Ar in air is 295.5 times less than that of <sup>40</sup>Ar, the error of calculation of the quantity of radiogenic argon is equal to  $\sim 1.5 \cdot 10^{-15}$  g. Under these circumstances, determination of the quantity of radiogenic <sup>40</sup>Ar using the CF-MS method with a precision of 1% requires a sample containing only  $1.5 \cdot 10^{-13}$  g of radiogenic <sup>40</sup>Ar.

In practical situations, other errors such as amplifier noise, ion current instability, contribution of isobaric masses, ratio of air and radiogenic argon, etc., will affect the limits of the precision. In this case, however, application of the CF-MS technique to measure Ar isotopes is a very promising and attractive prospect. We therefore developed a technique for the measurement of Ar isotopes in a He flow by IRMS for K/Ar geochronology.

## EXPERIMENTAL

The installation for the extraction and measurement of Ar isotopes consists of several in-series connected systems: (1) a high-vacuum line of argon release; (2) a coupling interface of a high-vacuum line and a He flow line; and (3) a MAT-253 mass spectrometer (ThermoFinnigan, Bremen, Germany) (Fig. 1).

### The high-vacuum line

This system is assembled from bellows valves (V 1–5) connected by stainless steel tubes of 6-mm o.d. A U-shaped cryogenic trap is made from a stainless steel tube. The entire system is pumped out by a turbomolecular pump providing a pressure of up to 10<sup>-8</sup> Torr. To release the argon, a continuous Nd-YAG infrared laser is used with multimode operation at a wavelength of 1.06 μm (maximum power is 100 W). The laser beam deflection and focusing are carried out by the focusing system (FS). The chamber for argon release is located above the laser beam focusing point, at a distance that allows a laser beam diameter of about 1 mm on the sample.

In the tracer injection system, a gas cylinder 1000 cm<sup>3</sup> in volume containing the monoisotope <sup>38</sup>Ar is used. The internal surface of the gas cylinder is enameled and guarantees the long-term use of the tracer practically without changing the isotopic composition. Before installation, the gas cylinder is heated and degassed by pumping to high vacuum and filled with the tracer <sup>38</sup>Ar to about 2000 ng. The dosing mechanism with a dosage volume of  $\sim 0.2$  cm<sup>3</sup> is installed between the gas cylinder and vacuum system.

In our system, argon is extracted in the chamber. The chamber is made of stainless steel (Fig. 2) and consists of a cylindrical body frame (1), an upper flange (2) for vacuum sealing of the quartz window, and a lower flange (3). A gold ring (5) is used for vacuum sealing of the quartz window, and a copper gasket (6) is used to seal the lower flange. The i.d. of

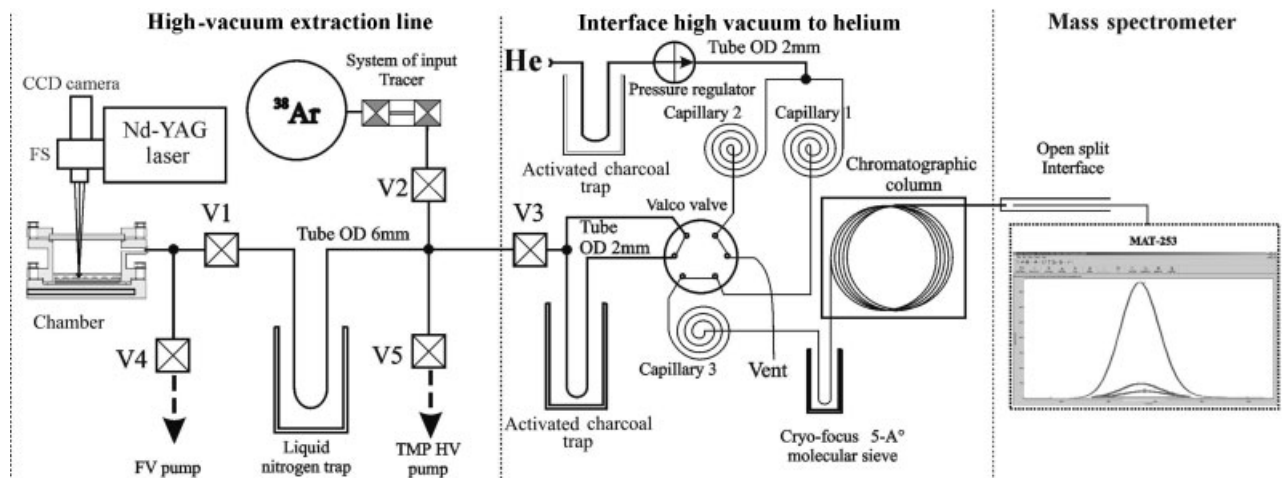
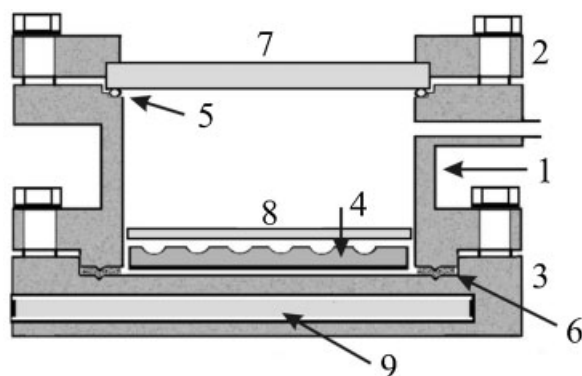

**Figure 1.** Schematic diagram showing the basic setup for extraction and measurement of argon isotope composition. FS – laser beam deflection and focusing system. V (1–5) – high-vacuum bellows valves. FV – forvacuum pump. TMP – turbomolecular pump.

the chamber is 32 mm and its height is 30 mm. The entrance window is made of quartz glass (7) with a thickness of 5 mm, and it is transparent for the emission wavelength of the Nd-YAG laser. The multiple-charge holder for small samples (no more than 5 mg) is made of a nickel disk, with a diameter of 30 mm and thickness of 5 mm. In the holder, 30 holes each with a depth of 2.5 mm and diameter of 3 mm were drilled. For samples with a greater weight, but not exceeding 20 mg, separate quartz cups with an outside diameter of 10 mm and height of 5 mm are used. The chamber can simultaneously contain 9–10 cups and the total weight of one sample can therefore reach 200 mg. To prevent the ejection of samples grains from holes, the multiple-charge holder and cups are covered with a screen of quartz glass with a thickness of 2 mm (8).

### Interface between the high-vacuum line and the line of continuous He flow

The interface includes a bellows valve V3, a six-port Valco valve, a trap with activated charcoal, a trap for cryofocusing of Ar, quartz capillaries, and a temperature-controlled chromatographic column. The trap with the activated charcoal



**Figure 2.** Schematic diagram of the high-vacuum chamber. 1: chamber; 2, 3: lower and upper flanges; 4: multiple-charge sample holder; 5: gold vacuum seal rings; 6: copper vacuum seal; 7, 8: quartz glasses; 9: chamber heater.

is made of a stainless steel tube with an o.d. of 1.6 mm. A part of the tube cooled by liquid nitrogen is filled with activated charcoal. The condensed Ar in the trap can be separated from the extraction line by closing the V3 valve. The trap with the activated charcoal is filled with He when the Valco valve is switched over. In order to obtain the sharply focused ion peak in the mass spectrometer, Ar is transported from the cryogenic trap in the He flow and condensed in the cryofocusing trap. This cryofocusing trap is made of a section of a HP-MOLSIV 5A OD 0.32 capillary chromatographic column (Varian Inc., Palo Alto, CA, USA) and is directly connected to the capillary chromatographic column (also HP-MOLSIV 5A OD 0.32, with a length of 25 m). The trap with the molecular sieve is heated to room temperature and gases are re-injected into the He carrier gas flow. A mixture of gases is passed to the chromatographic column where they are separated, and pure Ar in the He flow is transported through the open splitter into the ion source of the mass spectrometer. The operating temperature of the thermostat is 25°C. The He flow through the chromatographic column is 2 cm<sup>3</sup>/min, and the flows of He through the column and the cryofocusing system are set by the quartz capillaries (1, 2 and 3). Helium (with a purity of 99.9999%) enters the chromatographic column through the cryogenic trap with activated charcoal for additional cleanup and, in particular, for freezing-out from the He of small admixtures of Ar. It should be noted that, at the He flow rate of 2–4 cm<sup>3</sup>/min, one gas cylinder of He can be used for a period of more than 1 year.

### Mass spectrometer

The mass spectrometer is operated in dynamic mode and measurements of the isotope composition of argon are made simultaneously on three collectors with input resistances of  $1 \cdot 10^{12}$ ,  $3 \cdot 10^{11}$  and  $1 \cdot 10^{11}$  Ohm for <sup>36</sup>Ar, <sup>38</sup>Ar and <sup>40</sup>Ar, respectively. The investigated argon is injected into the ion source in the He flow through the open split. The MAT-253 mass spectrometer is equipped with an additional module of differential pumping to ensure optimum vacuum conditions even with large He inflows into the ion source. Modern ion sources allow the measurement of isotope ratios in He flows

of up to  $0.5 \text{ cm}^3/\text{min}$ . Therefore, the He flow of  $2 \text{ cm}^3/\text{min}$  is split before being introduced into the mass spectrometer. This is achieved for the sample gas using a fused-silica capillary, 1500 mm in length with an i.d. of 0.1 mm, which sucks the sample carrier gas stream. The sucking region of the open split has the shape of a test glass tube that is flushed with He to avoid atmospheric contamination. In this case, a vacuum in the chromatographic column is not produced and the chromatographic resolution remains unchanged. Helium passes through the open split and the flow is divided, resulting in only 25% entering the ion source. The efficiency of the open split can be increased by reducing the He flow rate. However, a flow of at least  $2\text{--}4 \text{ cm}^3/\text{min}$  is needed to obtain a satisfactory operation of the capillary column. The excess He flow is also necessary for complete screening of the suction capillary in the open split to prevent atmospheric air from entering the ion source. Therefore, we used a minimum He flow through the column of  $2 \text{ cm}^3/\text{min}$ .

The three ion beams of  $^{36}\text{Ar}$ ,  $^{38}\text{Ar}$  and  $^{40}\text{Ar}$  are registered simultaneously by a multiple Faraday cup arrangement with a dedicated voltage-to-frequency converter for each isotope. The resulting ion currents are continuously monitored, then digitized and transferred to the host computer. The peak area for each isotope is then integrated quantitatively and calculated. Knowing the absolute quantity of dosed monoisotope  $^{38}\text{Ar}$ , one can determine the quantity of radiogenic argon using conventional calculation methodology.<sup>19</sup> The measurement of peak area of ion current for the three argon isotopes is carried out under the control of ISODAT-NT software (ThermoFinnigan).

### Principle of operation

Before argon extraction, the chamber is wiped using a napkin moistened with alcohol. The nickel sample holder or quartz cups are washed with distilled water, subjected for a period of 15 min to ultrasonic cleaning in alcohol, and then dried at  $120^\circ\text{C}$ . The samples are placed in succession in cells of the nickel holder and put into the chamber. The high-vacuum system is pumped out to a pressure of  $10^{-8}$  Torr and heated at  $200\text{--}250^\circ\text{C}$  for 10–12 h. After the chamber cools to room temperature, the blank of the system is checked. When the laser is switched to full power, the blank does not differ in argon quantity from that of the switched-off laser, and therefore all checks of the blank are carried out when the laser is switched off.

Prior to melting of the sample, the monoisotope  $^{38}\text{Ar}$  is dosed into the high-vacuum system. Naturally, there is a gradual decrease of the quantity of  $^{38}\text{Ar}$  in the gas cylinder

during the tracer dosage.<sup>20</sup> In our case, the ratio of the gas cylinder volume to the dosing unit volume is equal to  $\sim 5000$ . With approximately 45 dosages of the tracer, the quantity of  $^{38}\text{Ar}$  actually decreased by 1% and this finding should be taken into account in calculations of the amount of radiogenic argon. After injection of the tracer, Dewar vessels with liquid nitrogen are put on the cryogenic trap and the trap with activated charcoal (Fig. 1). The laser beam is directed onto the investigated sample and switched on. The laser beam power is gradually increased to the maximum level, and the laser beam then gradually scans the whole surface of the cell or quartz cup. Generally, less than 1 min is required to completely melt the sample in the nickel holder. The time required for the complete melting of a sample in a quartz cup can reach 3–5 min due to the larger weights of these samples. On melting the sample, the extracted gases pass through the cryogenic trap (Fig. 1), where water and carbon dioxide condense. The residual gases together with Ar are condensed in the trap with activated charcoal through the open V3 valve (Fig. 3(A)). Full freezing-out of the extracted Ar takes 5–6 min. A Dewar vessel with liquid nitrogen is put on the cryofocusing trap with a molecular sieve, valve V3 is closed and the six-port valve is switched over (Fig. 3(B)). The trap with the molecular sieve is filled with He for 1 min and the Dewar vessel is taken off the activated charcoal trap. The trap is defrosted and the Ar re-condenses in the capillary trap with the molecular sieve for 1 min. The six-port valve is then switched to injection mode, the Dewar vessel is removed, and the gases are injected into the He carrier gas flow to the capillary chromatographic column. Generally, the entire high-vacuum system and the activated charcoal trap are pumped out to a high vacuum as these operations take place. When using the quartz cup, the overall cycle is prolonged by 3–5 min. After these operations, the system is ready for the subsequent release of Ar.

In the chromatographic column, the initial multicomponent mixture of gases is divided by the time of outlet into a number of binary mixtures consisting of the carrier gas and one of components. Argon is separated from possible contaminants in the chromatographic column and is injected through the open split into the ion source of the MAT-253. After using electrometric amplifiers, the detected signals are digitized and calculated as areas of the ion current peak for  $^{36}\text{Ar}$ ,  $^{40}\text{Ar}$  and tracer  $^{38}\text{Ar}$  (Fig. 4) under the control of the Isodat Acquisition program as a part of the ISODAT NT software for the MAT-253 mass spectrometer.

To account for the  $^{40}\text{Ar}/^{36}\text{Ar}$  ratio, calibration of the mass spectrometer is made using Ar with an atmospheric isotopic

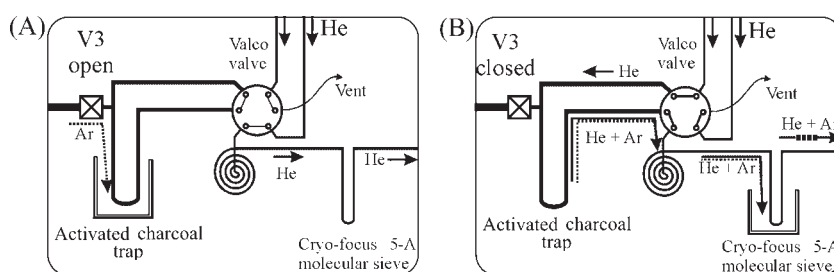

**Figure 3.** Schematic flow diagram for condensing of argon (A) and cryo-focusing and injection of Ar into the He flow (B).

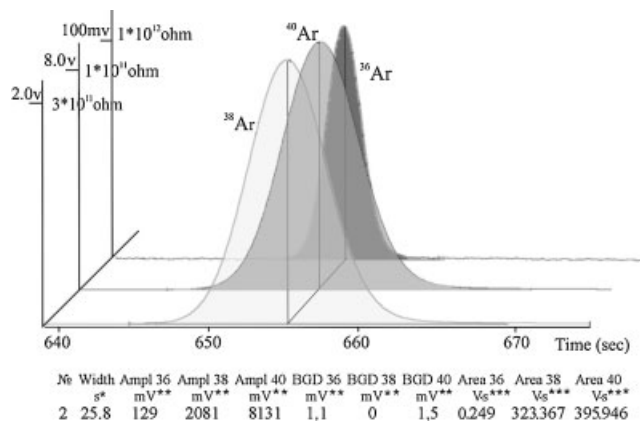

**Figure 4.** The timeline of the IRMS measurement protocol implemented in the ISODAT NT software (using the example of interlaboratory standard biotite). The sample weight is 0.27 mg. For ease of visualization, the peaks of  $^{36}\text{Ar}$ ,  $^{40}\text{Ar}$  and tracer  $^{38}\text{Ar}$  are spaced. On the ordinate axes are specified the intensity and corresponding entrance resistor of the electrometric amplifiers. In the table, the peak areas of the ion currents of the Ar isotopes were recalculated for resistance of  $1 \cdot 10^{12}$  Ohm. Width  $S^*$  – width of peak in seconds, BGD  $\text{mV}^{**}$  – background values in mV, Ampl  $\text{mV}^{**}$  – amplitude in mV, and  $\text{mV s}^{***}$  – the area in  $\text{mV} \cdot \text{s}$ .

composition. The measured  $^{40}\text{Ar}/^{36}\text{Ar}$  ratio was equal to 297.3 (with consideration for input resistance). However, a ratio of 295.5 was also obtained and differed from the standard ratio due to a slight difference of the nominal value of input resistances of the electrometric amplifiers for masses 36 and 40 and the discrimination of masses.

## RESULTS AND DISCUSSION

Small amounts of radiogenic argon extracted from geological samples require high stability, low backgrounds, minimal content of argon in the blank experiment, and high sensitivity of the isotope ratio mass spectrometer. After adjustment of the MAT-253 mass spectrometer ion source, an absolute sensitivity of one ion per 790 atoms of  $^{40}\text{Ar}$  was reached with an emission current of 1.5 mA. The abundance sensitivity of the mass spectrometer does not exceed  $2 \cdot 10^{-6}$  on mass 45. The background reduction is traditionally attained by heating of the entire complex (argon extraction system, purification system and mass spectrometer). The MAT-253 mass spectrometer requires a single heating of the ion source at 200–250°C for a period of 2 days. Furthermore, when using helium He-6.0 (with a purity of 99.9999%) with additional cleaning on the trap with activated charcoal at liquid nitrogen temperature, the background was lowered to  $1.5 \cdot 10^{-15}$  A for  $^{36}\text{Ar}$ , practically to zero for  $^{38}\text{Ar}$ , and to  $15 \cdot 10^{-15}$  A for the isotope  $^{40}\text{Ar}$ . This device background remained unchanged for a period of more than 1 year.

The necessary condition for measuring small amounts of argon isotopes is a minimal blank. To obtain a blank with a low content of atmospheric argon, the high-vacuum system together with the chamber are heated for 10–12 h at 200–250°C. The results of the blank measurement set for a period of 10 min are given in Table 1. All these and later results are

**Table 1.**  $^{40}\text{Ar}$  blank of entire system including high-vacuum line of laser argon extraction; interface of high-vacuum line – helium flow line; MAT-253 mass spectrometer

Measurement date	$^{36}\text{Ar}$ (area V s)	$^{36}\text{Ar}$ (g)	$^{40}\text{Ar}$ (area V s)	$^{40}\text{Ar}$ (g)
06/07/07	0.029	$\sim 2 \cdot 10^{-15}$	8.85	$\sim 6 \cdot 10^{-12}$
07/08/07	0.029		8.58	
08/10/07	0.032		9.59	
01/23/08	0.034		10.5	
02/14/08	0.021		6.38	
03/05/08	0.022		6.42	
04/09/08	0.023		6.90	
05/17/08	0.022		7.19	
06/03/08	0.023		6.99	
07/22/08	0.022		6.38	

re-counted as area of peak for  $^{36}\text{Ar}$ ,  $^{38}\text{Ar}$  and  $^{40}\text{Ar}$  in V s at an input resistance of  $10^{12}$  Ohm and a He flow rate of  $2 \text{ cm}^3/\text{min}$ .

On average, the system blank equaled  $6 \cdot 10^{-3}$  ng and it was stable over a long period of time. The blank values obtained by this study ranged from  $10 \cdot 10^{-3}$  to  $3 \cdot 10^{-3}$  ng and practically coincide with the results of the 'hot' blank experiment on the measuring complex 'mass spectrometer + argon released system' with a vacuum-isolated heater,<sup>21</sup> but they are inferior to the best blanks for laser systems of argon release.<sup>5</sup>

A certain part of the Ar is introduced into the blank of our system from the residual Ar in the He. To measure this part, the V3 valve is closed, the six-port valve is switched over to pass He through the cryofocusing system (Fig. 3(B)), the Dewar vessel with liquid nitrogen is placed on the trap with a molecular sieve, and Ar condenses from the He flow in the capillary trap for 10 min. The amount of Ar did not exceed 0.6 V s or  $\sim 5 \cdot 10^{-13}$  g of  $^{40}\text{Ar}$ . This is ten times lower than the amount of Ar in the blank of the entire system.

For correct calculation of the amount of radiogenic argon, it is necessary to know the  $^{38}\text{Ar}/^{36}\text{Ar}$  and  $^{38}\text{Ar}/^{40}\text{Ar}$  ratios in the tracer. For this purpose, the Ar isotope ratios in the tracer were measured with the double-inlet system and yielded the following isotope ratios:  $^{38}\text{Ar}/^{36}\text{Ar} = 1656 \pm 3$ ,  $^{38}\text{Ar}/^{40}\text{Ar} = 1451 \pm 4$ .

After obtaining all the necessary information concerning the background conditions, blank values and Ar isotope ratios in the tracer, calibration measurements of the amount of  $^{38}\text{Ar}$  in one dose were carried out. For calibration, interlaboratory standards with known amounts of radiogenic argon were used: Biotite-Chernaya Salma ( $^{40}\text{Ar}_{\text{RAD}} = 1689 \text{ ng/g}$ ), Muscovite-Chernaya Salma ( $^{40}\text{Ar}_{\text{RAD}} = 1861 \text{ ng/g}$ ),<sup>22</sup> and Hornblende-MMhb-1 ( $^{40}\text{Ar}_{\text{RAD}} = 65.04 \text{ ng/g}$ )<sup>23</sup> (Table 2). The samples were weighed using an ME-5 balance (Sartorius, Goettingen, Germany) with an error of  $\pm 0.1 \mu\text{g}$ . The weights of standards varied from 9 to 0.2 mg and corresponded to amounts of radiogenic argon from 7.8 to 0.13 ng. The amount of radiogenic argon  $^{40}\text{Ar}_{\text{RAD}}$ , measured in nanograms (ng), was calculated using the following expression:

$$^{40}\text{Ar}_{\text{RAD}} = ^{40}\text{Ar}_{\text{MEAS}} - ^{38}\text{Ar}_{\text{MEAS}}/1451 - (^{36}\text{Ar}_{\text{MEAS}} - ^{38}\text{Ar}_{\text{MEAS}}/1656) \cdot 297 \quad (1)$$

**Table 2.** Calibration of monoisotope  $^{38}\text{Ar}$  amount contained in one dose of tracer

Standard	Sample (mg)	$^{36}\text{Ar}_{\text{meas}}$ (area V s)	$^{38}\text{Ar}_{\text{meas}}$ (area V s)	$^{40}\text{Ar}_{\text{meas}}$ (area V s)	$^{40}\text{Ar}_{\text{rad}}$ (area V s)	$^{40}\text{Ar}_{\text{air}}$ (%)	Tracer ( $^{38}\text{Ar}$ ng)
Biotite-Chernaya Salma $^{40}\text{Ar}_{\text{RAD}}$ 1689 ng/g	0.1735	0.225	319	244	234	4	0.399
	0.2107	0.223	322	294	286	3	0.401
	0.3898	0.243	327	523	509	3	0.423
	0.5143	0.214	323	682	676	1	0.415
	0.8032	0.248	323	1093	1077	1	0.407
	1.0719	0.369	324	1445	1394	4	0.421
	2.0722	0.306	323	2739	2706	1	0.418
	3.9687	1.533	328	5713	5317	7	0.414
Average				$0.412 \pm 0.009$			
Muscovite-Chernaya Salma $^{40}\text{Ar}_{\text{RAD}}$ 1861 ng/g	0.5053	0.242	322	744	730	2	0.415
	0.6028	0.250	324	931	915	2	0.397
	0.7428	0.247	325	1121	1106	1	0.406
	1.0005	0.465	325	1553	1473	5	0.411
	4.1466	0.702	327	6287	6137	2	0.411
Average				$0.408 \pm 0.007$			
Hornblende-MMhb-1 $^{40}\text{Ar}_{\text{RAD}}$ 65.04 ng/g	2.0248	0.392	326	163	105	36	0.409
	2.0642	0.221	321	114	106	7	0.407
	3.6038	0.225	326	197	189	4	0.405
	4.0364	0.282	324	231	205	11	0.414
	4.0453	0.435	325	277	206	26	0.415
	5.4131	0.229	325	290	280	3	0.408
	9.0909	0.235	325	477	465	3	0.413
Average				$0.410 \pm 0.004$			

and the final amount of  $^{38}\text{Ar}$  in ng was calculated as:

$$^{38}\text{Ar}_{\text{ng}} = (P_{\text{ST}} \cdot ^{40}\text{Ar}_{\text{ST}}) \cdot ^{38}\text{Ar}_{\text{MEAS}} / ^{40}\text{Ar}_{\text{RAD}} \quad (2)$$

where  $^{38}\text{Ar}_{\text{MEAS}}$ ,  $^{38}\text{Ar}_{\text{MEAS}}$  and  $^{40}\text{Ar}_{\text{MEAS}}$  are the values of the area measured for the argon peak in V s,  $P_{\text{ST}}$  is the standard sample weight, and  $^{40}\text{Ar}_{\text{ST}}$  is the amount of radiogenic argon in 1 g of the standard. The results of the tracer amount measurement are given in Table 2 and take into account a correction for its gradual reduction on dosages of the tracer.<sup>20</sup>

Results obtained for the calibration amounts of the tracer  $^{38}\text{Ar}$  equal  $4.10 \cdot 10^{-10} \pm 4 \cdot 10^{-12}$ ,  $4.12 \cdot 10^{-10} \pm 9 \cdot 10^{-12}$  and  $4.08 \cdot 10^{-10} \pm 7 \cdot 10^{-12}$  g for the standards MMhb-1, Biotite-Chernaya Salma and Muscovite-Chernaya Salma, respectively, and these are practically equal to each other with regard to the limits of accuracy. In fact, these data are an estimation of the accuracy of the measurement of the argon amount with the proposed method. The precision of the definition of the argon amount is a function of several experimentally determined values. The precision of  $^{40}\text{Ar}_{\text{RAD}}$  in expression (1) is equal to the sum of measurement errors of  $^{40}\text{Ar}_{\text{MEAS}}$ ,  $^{38}\text{Ar}_{\text{MEAS}}$  and  $^{36}\text{Ar}_{\text{MEAS}}$ . In turn, the error of measured values is the sum of internal errors of the mass spectrometer and errors from the system of argon extraction. The internal precision of the measurement of the area of the ion current peak for  $^{36}\text{Ar}_{\text{MEAS}}$  is determined by the signal-to-noise ratio. For example, in modern mass spectrometers a signal of 100 mV results in a peak width of 5 s being measured with a precision that is not worse than 0.2 mV ( $R = 10^{12}$  Ohm). The areas of the  $^{36}\text{Ar}_{\text{MEAS}}$  peaks presented in Table 2 vary from 0.214 to 1.533 V s and they were measured with an error better than  $\pm 0.1$  mV s. The areas of the  $^{40}\text{Ar}_{\text{MEAS}}$  and  $^{38}\text{Ar}_{\text{MEAS}}$  peaks are hundreds of times greater than that of the  $^{36}\text{Ar}_{\text{MEAS}}$  peak and the precision of their measurement will therefore be ten times better.<sup>18</sup> The errors

associated with the calculation of isotope ratios  $^{38}\text{Ar}/^{36}\text{Ar}$ ,  $^{38}\text{Ar}/^{40}\text{Ar}$  in the tracer and  $^{40}\text{Ar}/^{36}\text{Ar}$  in air are characterized as regular errors. Therefore, the error of calculating the radiogenic argon amount is determined by the precision of the  $^{36}\text{Ar}_{\text{MEAS}}$  measurement because the sum of remaining errors is of minor significance. The maximum error of  $^{40}\text{Ar}_{\text{RAD}}$  determination will be equal to  $\sim 0.1 \cdot 297$  mV s or  $\sim 4 \cdot 10^{-14}$  g. The error of  $4 \cdot 10^{-14}$  ng is the internal error of the mass spectrometric measurement.

Additional error is introduced in the calculation of  $^{40}\text{Ar}_{\text{RAD}}$  by error resulting from the level of completeness of radiogenic argon released, error in the tracer dosage, and, in our case, error from the stability of the stream of He. The complete extraction of radiogenic argon is not in doubt because an extraction of radiogenic argon on re-heating of the sample was not observed. Instability of the He stream simultaneously influences the  $^{38}\text{Ar}$  and  $^{40}\text{Ar}$  ion current intensity, and in this case the error must be very small when considering the IT Principle. The design of our dosing unit is similar to that described by Miille<sup>20</sup> for which the maximal error of a gas dosage volume was equal to  $\pm 0.03\%$ , such that the error when using a dose of  $^{38}\text{Ar}$  for the calculation of the quantity of radiogenic argon should not exceed  $\pm 1.3 \cdot 10^{-13}$  g. The amount of the air argon admixture influences the precision of the radiogenic argon calculation.<sup>24</sup> In the measured standards, the contribution of atmospheric argon varied from 36% to 1% (Table 2). For such an amount of atmospheric argon, the error of the radiogenic argon calculation has practically no impact on the final results.<sup>21,24</sup> In the end, the total error for the determination of the amount of  $^{40}\text{Ar}_{\text{RAD}}$  in our system should not exceed  $\pm 2 \cdot 10^{-13}$  g.

It is evident from expression (2) that the error in calculating the  $^{38}\text{Ar}$  amount in nanograms is equal to a sum of the sample weighing error, the precision of  $^{38}\text{Ar}_{\text{MEAS}}$  determination,

**Table 3.** Comparison of results of K/Ar dating obtained by CF-MS and classical methods

#	Sample	Rock, Mineral	CF-MS method			Classical method Million years
			$^{40}\text{Ar}_{\text{AIR}}$ %	$^{40}\text{Ar}_{\text{RAD}}$ ng	Million years	
1	F-899/6	Biotite	15	0.213	80 ± 3	82 ± 2
2	P-517/9	Obsidian	5.6	0.126	29 ± 2	24 ± 5
3	P-571	Basalt	56.1	0.006	13 ± 2	14 ± 5
4	Y-02-17	Basalt	24.3	0.099	37 ± 2	38 ± 2
5	Y-02-19	Basalt	9.5	0.120	43 ± 2	41 ± 2
6	Y-02-21	Basalt	13.6	0.065	30 ± 1	31 ± 2
7	GV-412	Muscovite	9.2	0.086	67 ± 2	67 ± 2
8	GV-18	Biotite	21	0.154	104 ± 3	102 ± 2
9	A-185	Biotite	23	0.053	67 ± 2	65 ± 2

and the precision of the determined amount of  $^{40}\text{Ar}_{\text{RAD}}$ . For the sample with a minimum weight of standard (0.1735 mg), the weighing error is 0.06% and corresponds to an error of argon determination in this sample of  $\sim 1.8 \cdot 10^{-13}$  g. For the remaining samples, the weighing error is several times lower. Accordingly, the maximum error of calculating the  $^{38}\text{Ar}$  amount of the tracer in nanograms when considering the errors of  $^{38}\text{Ar}_{\text{MEAS}}$  (tens times smaller),  $^{40}\text{Ar}_{\text{RAD}}$  ( $\sim 2 \cdot 10^{-13}$  g) and the weighing error ( $1.8 \cdot 10^{-13}$ ) is equal to  $\sim 4 \cdot 10^{-13}$  g.

The average reproducibility of the tracer calibration (Table 2) is  $\pm 7 \cdot 10^{-12}$  g, which is ten times greater than the maximum error of measuring one dose of the tracer  $^{38}\text{Ar}$  ( $4 \cdot 10^{-13}$  g). Many researchers repeatedly mark variations of the amount of radiogenic argon in the standard MMhb-1 at a sample weight of less than 10 mg.<sup>25–27</sup> For a sample weight of less than 10 mg, the measurement error goes up to  $\pm 1\%$ .<sup>28</sup> Data for the Biotite-Chernaya Salma and Muscovite-Chernaya Salma standards are absent. At the same time, results for the calibration of these standards in different laboratories have revealed that the divergence of age calculation reaches  $\pm 5\%$ .<sup>22</sup> The reproducibility obtained for the amount of the tracer  $^{38}\text{Ar}$  is probably related in many respects to the heterogeneity of standards when the sample weights of the Biotite-Chernaya Salma, Muscovite-Chernaya Salma and MMhb-1 standards are less than 10 mg.

The errors associated with the determination of radiogenic argon in geological samples depend on the peculiarities of samples and the empirical error of the age calculation, which can differ substantially from that attained in the case of analyzed standards. The results of dating for several samples obtained in other laboratories were compared with results of measurements of the same samples using the CF-MS technique (Table 3). Values of constants accepted internationally and recommended by the IUGS Subcommittee on Geochronology<sup>29</sup> were used for the calculation of age. The potassium contents in samples were taken from the results of measurements made in other laboratories where analyses of argon were carried out. In our experiments, the weights of samples varied from 31.3 to 2.0 mg and the amounts of extracted radiogenic argon varied from 0.2 to 0.006 ng. Each sample was analyzed at least three times. For all samples, the ages calculated from results of argon measurement by the CF-MS technique coincided with results obtained in other laboratories, within the limits of measurement errors.

Experiments involving the measurement of Ar isotopes in a stream of He using a MAT-253 mass spectrometer have

shown that the CF-MS method can be used for the analysis of  $6 \cdot 10^{-12}$  g amounts of radiogenic argon with an accuracy that is suitable for the solution of many geochronological problems. The measurement of such an amount of radiogenic argon is not the potential limit of the method as may be inferred from the calculation given in our substantiation of the CF-MS technique. In our installation, the open split is used with an argon efficiency of about 25%. For more efficient use of the open split, it is desirable to inject all the He flow from the chromatographic column into the ion source of the mass spectrometer. However, the maximum He flow of  $\sim 0.5 \text{ cm}^3/\text{min}$  to the mass spectrometer is limited by the space charge in the ion source. On the other hand, the efficiency of the open split can be increased by reducing the He flow through the chromatographic column to  $\sim 0.5 \text{ mL}/\text{min}$ , which would allow an almost 100% efficiency for the amount of Ar extracted from the sample. Another means of decreasing the amount of Ar would be to substitute the Faraday cup for  $^{36}\text{Ar}$  with an electron multiplier. The use of an electron multiplier will allow a decrease of the amount of Ar required for measurement with the CF-MS method by more than an order of magnitude.

## CONCLUSIONS

Experiments involving the measurement of Ar isotopes extracted from standards and real samples in a He flow using a MAT-253 mass spectrometer showed that the CF-MS technique can be used to analyze radiogenic argon in amounts of  $n \cdot 10^{-12}$  g. The accuracy and precision of these measurements are suitable for the solutions required for many geochronological problems. In principle, the CF-MS technique is an alternative to the technique of static measurements of Ar isotopes. The sensitivity and accuracy of the CF-MS method are not inferior to those of classical methods involving argon measurement with isotope dilution. The method of measurement using the dynamic-mode operation of a mass spectrometer with a continuous stream of He is more reliable and simpler than a method of Ar isotope measurement in a static mode. Results obtained by measuring small amounts of radiogenic argon do not reflect a limitation of the method. To realize the potential of the CF-MS technique, it is necessary to maximize the efficiency of the open split and to use an electron multiplier for  $^{36}\text{Ar}$  measurement. Even a cursory examination shows that the method can be easily adapted for the  $^{39}\text{Ar}/^{40}\text{Ar}$  method of

absolute geochronology and investigations concerning krypton and xenon isotopic composition.

### Acknowledgements

We are grateful to two anonymous reviewers for their helpful comments that improved the manuscript. This work was supported by the FEB RAS Grant No. 09-1-OH3-02.

### REFERENCES

1. Staudacher Th, Jessberger EK, Dorflinger D, Kiko J. *J. Phys. E. Sci. Instrum.* 1978; **11**: 781.
2. Karpenko MI, Ivanenko VV. *Geokhimiya* 1993; **10**: 1492 (in Russian).
3. Reynolds JH. *Rev. Sci. Inst.* 1956; **27**: 928.
4. McDougall I, Harrison TM. *Geochronology and Thermochronology by the  $^{40}\text{Ar}/^{39}\text{Ar}$  Method*, (2nd edn) Oxford University Press: New York, 1999.
5. Dalrymple GB. In *New Frontiers in Stable Isotopic Research: Laser Probes, Ion Probes, and Small-Sample Analysis*, Shanks WC III, Cris RE (eds). US Geological Survey Bulletin 1890, US Government Printing Office: 1989; 89.
6. Wright IP, Pillinger CT. In *New Frontiers in Stable Isotopic Research: Laser Probes, Ion Probes, and Small-Sample Analysis*, Shanks WC III, Cris RE (eds). US Geological Survey Bulletin 1890, US Government Printing Office: 1989; 9.
7. Franchi LA, Boyd SR, Wright IP, Pillinger CT. In *New Frontiers in Stable Isotopic Research: Laser Probes, Ion Probes, and Small-Sample Analysis*, Shanks WC III, Cris RE (eds). US Geological Survey Bulletin 1890, US Government Printing Office: 1989; 51.
8. Matthews DE, Hayes JM. *Anal. Chem.* 1978; **50**: 1465.
9. Brand WA. *J. Mass Spectrom.* 1996; **31**: 225.
10. Fry B. *Rapid Commun. Mass Spectrom.* 2007; **21**: 750.
11. Gehre M, Geilmann H, Richter J, Werner RA, Brand WA. *Rapid Commun. Mass Spectrom.* 2004; **18**: 2650.
12. Yun M, Mayer B, Taylor SW. *Rapid Commun. Mass Spectrom.* 2005; **19**: 1429.
13. Sharp ZD, Atudorei V, Durakiewicz T. *Chem. Geol.* 2001; **178**: 197.
14. Werner RA, Bruch BA, Brand WA. *Rapid Commun. Mass Spectrom.* 1999; **13**: 1237.
15. Brand WA. In *Handbook of Stable Isotope Analytical Techniques*, vol. I de Groot PA (ed). Elsevier: Amsterdam, 2004; 835.
16. Brand WA. *Adv. Mass Spectrom.* 1998; **14**: 655.
17. Inghram MG, Brawn H, Patterson C, Hess DC. *Phys. Rev.* 1950; **80**: 916.
18. Merritt DA, Hayes JM. *Anal. Chem.* 1994; **66**: 2336.
19. Dalrymple GB, Lanphere MA. *Potassium-Argon Dating Principles, Techniques and Applications to Geochronology*. W.H. Freeman and Co.: San Francisco, 1969.
20. Miille AP. *J. Res. Natl. Inst. Stand. Technol.* 2006; **111**: 335.
21. Chernyshev IV, Lebedev VA, Arakelyants MM. *Petrology* 2006; **14**: 62.
22. Starik IE. *Yadernaya geokhronologiya*. AN SSSR: Moscow, 1961; (in Russian).
23. Sampson SD, Alexander EC Jr. *Chem. Geol.* 1987; **66**: 27.
24. Cox A, Dalrymple GB. *J. Geophys Res.* 1967; **72**: 2603.
25. Baksi AK, Archibald DA, Farrar E. *Chem. Geol.* 1996; **129**: 307.
26. Ingamells CO, Engels JC. *Natl. Bur. Stand. Spec. Publ.* 1976; **422**: 403.
27. Renne PR, Swisher CC, Deino AL, Karner DB, Owens TL, DePaolo DJ. *Chem. Geol.* 1998; **145**: 117.
28. Spella TL, McDougalla I. *Chem. Geol.* 2003; **198**: 1.
29. Steiger RH, Jager E. *Earth Planet. Sci. Lett.* 1977; **36**: 359.